

WARN INDUSTRIAL HOIST

WINCH MODEL

PART NUMBER

TYPE

DC350

PN 63674

12V ELECTRIC

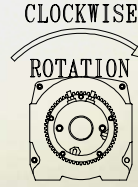

11/04/02

Rated for 350 kg, this compact hoist conforms to CE requirements. Its permanent magnet motor, 136:1 gear ratio and spring brake combine to ensure safe and reliable performance.

ENGINEERING DATA:

STANDARDS COMPLIANCE:

- **Maximum rated load :** 770 lbs (350 kg)
- **Maximum wire rope recommended:** 5/32" 2800 lbs (1273kg) minimum breaking strength
- **Drum barrel diameter:** 2.04" (52 mm)
- **Drum flange diameter:** 4.0" (102 mm)
- **Distance between flanges:** 2.87" (73 mm)
- **Approximate shipping weight:** 25 lbs (12 kg)
- **Gear ratio:** 136:1
- **Motor:** 12 volt DC permanent magnet 0.9 hp (0.67 KW)

- CE Electromagnetic Compatibility 89/336/EEC & 95/54/EC
- CE Machinery Directive 98/37/EEC
- ISO 4301-1, Machinery Class M3
- ISO 4301-2, Machinery Class M3
- ISO 4308-1, Machinery Class M3
- JCA, Class A

PERFORMANCE DATA:

AVAILABLE ACCESSORIES:

LAYER	LINE LOAD		LINE SPEED		5/32" (4mm) WIRE ROPE CAPACITY	
	lb.	kg	ft/m in.	m/m in.	ft.	meters
1	770	350	17.9	5.5	10	3.1
2	675	307	20.4	6.2	20	6.1
3	602	274	22.9	7.0	33	10.1
4	538	245	25.6	7.8	50	15.2
1 st LAYER	LINE LOAD		LINE SPEED		DUTY CYCLE	
	lb.	kg	ft/m in.	m/m in.	amps	min/10 min
	0	0	23.1	7.0	22	2.5
	220	100	20.9	6.4	36	2.0
	440	200	19.7	6.0	50	1.8
	770	350	17.9	5.5	70	1.3

- Contactor - pn 63926
- Remote Control—HD - pn 34462
- Remote Control—CE - pn 63680
- OverLoad Interrupt - pn 61929

WARN INDUSTRIES, INC. INDUSTRIAL PRODUCTS

12900 S.E. Capps Road, Clackamas, OR USA 97015-8903
 Customer Service (in North America): 1.800.543.9276
 Customer Service (International): 1.503.722.3054
 Fax:1.503.722.3000 www.warn.com



WARN INDUSTRIAL HOIST

WINCH MODEL	PART NUMBER	TYPE
DC350	PN 63674	12V ELECTRIC

DIMENSIONAL DATA

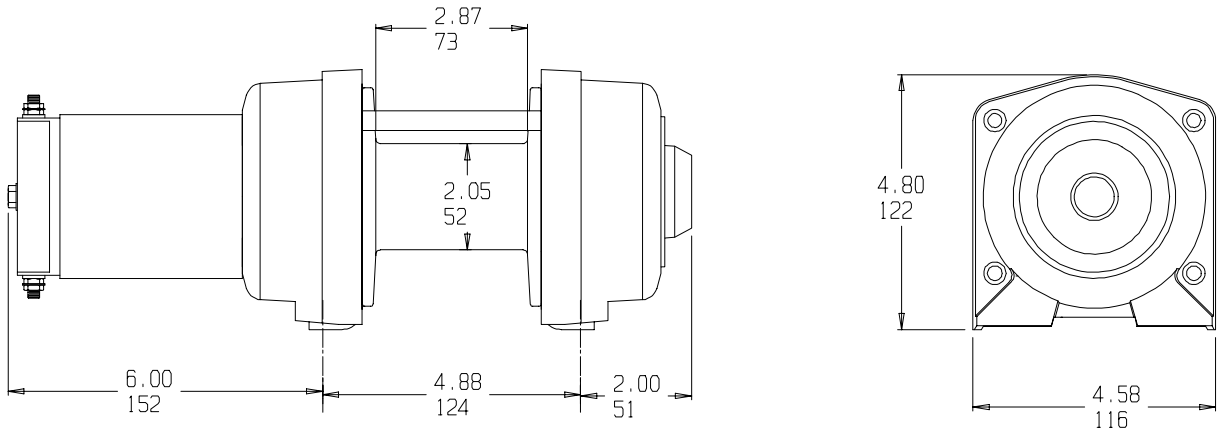

REPLACEMENT PARTS

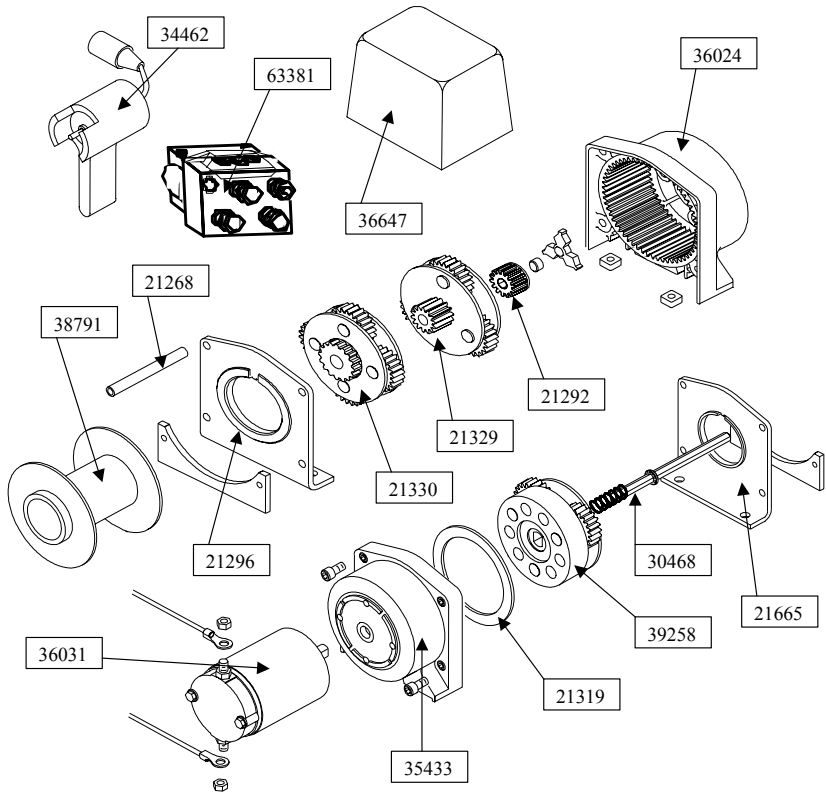

WARN INDUSTRIES, INC. INDUSTRIAL PRODUCTS

12900 S.E. Capps Road, Clackamas, OR USA 97015-8903
Customer Service (in North America): 1.800.543.9276
Customer Service (international): 1.503.722.3008
Fax: 1.503.722.3000 www.warn.com

