

WARN INDUSTRIAL HOIST

WINCH MODEL	PART NUMBER	TYPE
DC350	PN 63675	24V ELECTRIC



11/04/02

Rated for 350 kg, this compact hoist conforms to CE requirements. Its permanent magnet motor, 136:1 gear ratio and spring brake combine to ensure safe and reliable performance.

ENGINEERING DATA:

- **Maximum rated load :** 770 lbs (350 kg)
- **Maximum wire rope recommended:** 5/32" 2800 lbs (1273kg) minimum breaking strength
- **Drum barrel diameter:** 2.04" (52 mm)
- **Drum flange diameter:** 4.0" (102 mm)
- **Distance between flanges:** 2.87" (73 mm)
- **Contactors:** Industrial contactor with 12' (3.7 M) heavy duty remote control
- **Approximate shipping weight:** 25 lbs (12 kg)
- **Gear ratio:** 136:1
- **Motor:** 24 volt DC permanent magnet 0.9 hp (0.67 KW)

STANDARDS COMPLIANCE:

- CE Electromagnetic Compatibility 89/336/EEC & 95/54/EC
- CE Machinery Directive 98/37/EEC
- ISO 4301-1, Machinery Class M3
- ISO 4301-2, Machinery Class M3
- ISO 4308-1, Machinery Class M3
- JCA Class A

PERFORMANCE DATA:

LAYER	LINE LOAD		LINE SPEED		5/32" (4mm) WIRE ROPE CAPACITY	
	lb.	kg	ft/m in.	m/m in.	ft.	meters
1	770	350	17.9	5.5	10	3.1
2	675	307	20.4	6.2	20	6.1
3	602	274	22.9	7.0	33	10.1
4	538	245	25.6	7.8	50	15.2
1 st LAYER	LINE LOAD		LINE SPEED		DUTY CYCLE	
	lb.	kg	ft/m in.	m/m in.	amps	min/10 min
	0	0	23.1	7.0	12	2.5
	220	100	20.9	6.4	18	2.0
	440	200	19.7	6.0	26	1.8
	770	350	17.9	5.5	40	1.3

AVAILABLE ACCESSORIES:

- Contactor - pn 63752
- Remote Control—HD - pn 34462
- Remote Control—CE - pn 63680
- OverLoad Interrupt - pn 61930

WARN INDUSTRIES, INC. INDUSTRIAL PRODUCTS

12900 S.E. Capps Road, Clackamas, OR USA 97015-8903
 Customer Service (in North America): 1.800.543.9276
 Customer Service (International): 1.503.722.3054
 Fax:1.503.722.3000 www.warn.com



WARN INDUSTRIAL HOIST

WINCH MODEL	PART NUMBER	TYPE
DC350	PN 63675	24V ELECTRIC

DIMENSIONAL DATA

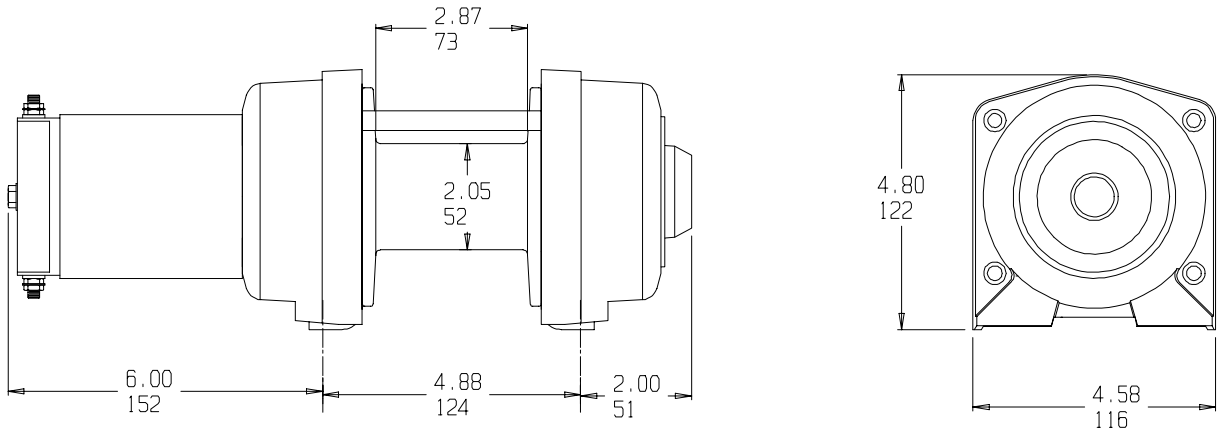

REPLACEMENT PARTS

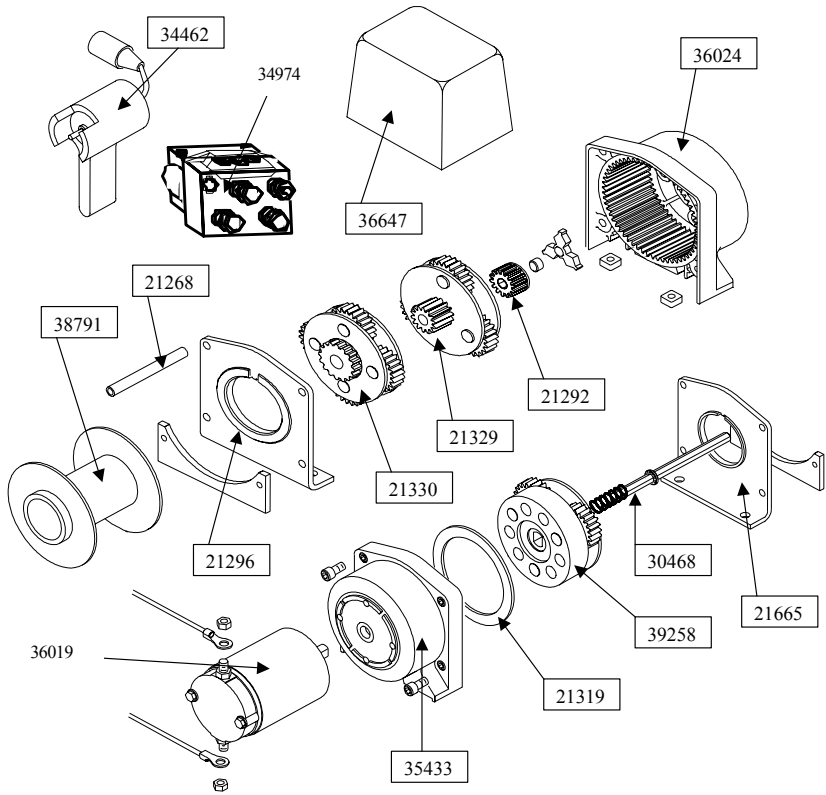

WARN INDUSTRIES, INC. INDUSTRIAL PRODUCTS

12900 S.E. Capps Road, Clackamas, OR USA 97015-8903
Customer Service (in North America): 1.800.543.9276
Customer Service (international): 1.503.722.3008
Fax: 1.503.722.3000 www.warn.com

