

WARN INDUSTRIAL HOIST

WINCH MODEL	PART NUMBER	TYPE
DC500	PN 63676	12V ELECTRIC

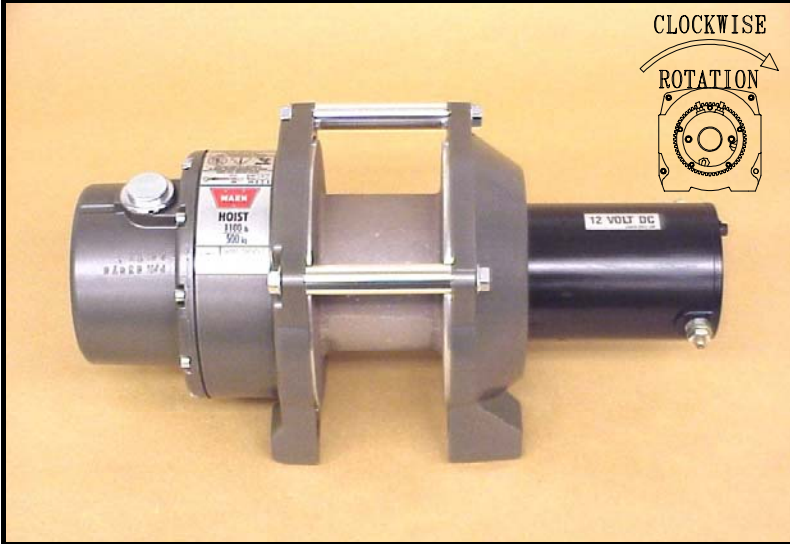

11/04/02

Rated for 500 kg, this compact hoist conforms to CE requirements. Its permanent magnet motor, 261:1 gear ratio and dual cone brake combine to ensure safe and reliable performance.

ENGINEERING DATA:

- **Maximum rated load :** 500 kg (1100 lbs)
- **Maximum wire rope recommended:** 3/16" 4200 lbs (1909kg) minimum breaking strength
- **Drum barrel diameter:** 3.5" (89 mm)
- **Drum flange diameter:** 6.0" (152 mm)
- **Distance between flanges:** 2.7" (69 mm)
- **Contactors:** Industrial contactor with 12' (3.7 M) heavy duty remote control
- **Approximate shipping weight:** 25 lbs (12 kg)
- **Gear ratio:** 261:1
- **Motor:** 12 volt DC permanent magnet 1.1 hp (0.82 KW)

STANDARDS COMPLIANCE:

- CE Electromagnetic Compatibility 89/336/EEC & 95/54/EC
- CE Machinery Directive 98/37/EEC
- ISO 4301-1, Machinery Class M3
- ISO 4301-2, Machinery Class M3
- ISO 4308-1, Machinery Class M3
- JCA Class A

PERFORMANCE DATA:

LAYER	LINE LOAD		LINE SPEED		3/16" (5mm) WIRE ROPE CAPACITY	
	lb.	kg	ft/m in.	m/m in.	ft.	meters
1	1100	500	16.9	5.2	13	4.0
2	965	439	19.3	5.9	26	7.9
3	859	390	21.6	6.6	41	12.5
4	775	352	24.0	7.3	58	17.7
1 st LAYER	LINE LOAD		LINE SPEED		DUTY CYCLE	
	lb.	kg	ft/m in.	m/m in.	amps	min/10 min
	0	0	21.3	6.5	38	6.0
	500	227	19.5	5.9	65	4.2
	750	341	18.4	5.6	78	3.3
	1100	500	16.9	5.2	99	2.5

AVAILABLE ACCESSORIES:

- Contactor - pn 63926
- Remote control -HD - pn 34462
- Remote control - CE - pn 63680
- OverLoad Interrupt - pn 61929

WARN INDUSTRIES, INC. INDUSTRIAL PRODUCTS

12900 S.E. Capps Road, Clackamas, OR USA 97015-8903
 Customer Service (in North America): 1.800.543.9276
 Customer Service (International): 1.503.722.3054
 Fax:1.503.722.3000 www.warn.com



WARN INDUSTRIAL HOIST

WINCH MODEL	PART NUMBER	TYPE
DC500	PN 63676	12V ELECTRIC

DIMENSIONAL DATA

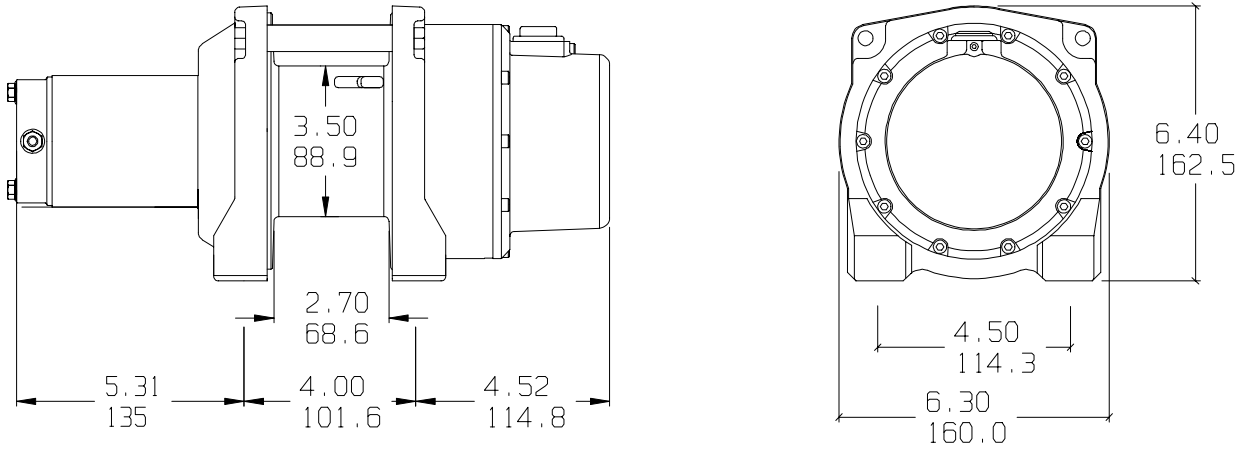

REPLACEMENT PARTS

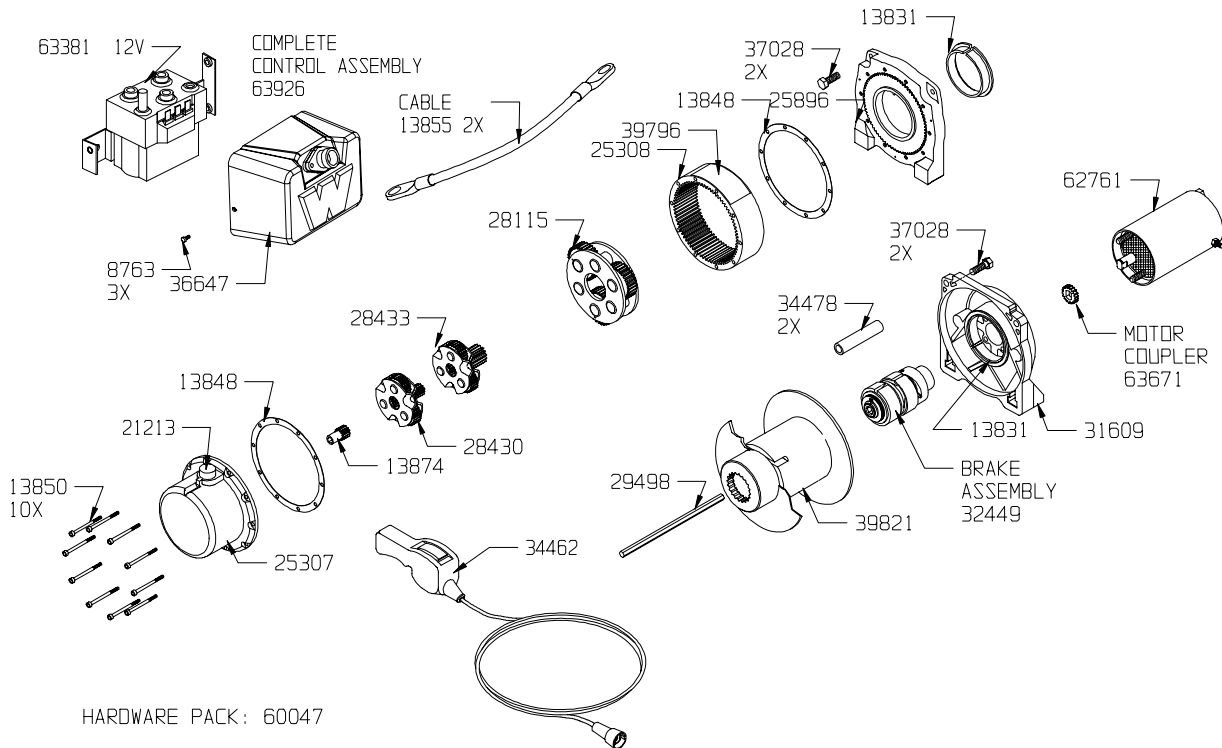

WARN INDUSTRIES, INC. INDUSTRIAL PRODUCTS

12900 S.E. Capps Road, Clackamas, OR USA 97015-8903
 Customer Service (in North America): 1.800.543.9276
 Customer Service (international): 1.503.722.3008
 Fax: 1.503.722.3000 www.warn.com

